





# Cryogenic Dry Disconnect Couplings



## Applications:

- container discharge
- fuel bunkering
- loading / unloading of tank trucks, rail cars and ship tankers, over 6,000 LNG fueling operations since 2013
- vapor recovery lines

## Sizes:

- 1" - 6"

## Material:

- stainless steel

## Features:

- single action operation uses a straight forward turning motion to connect the couplings and open the flow path
- safe and reliable: valve cannot be opened until the unit is coupled and it closes automatically when disconnecting, eliminating spills
- used with a wide range of cryogenic liquefied gases without the risk of cross connection due to human error

## Specifications:

- connections: female NPT, flanged EN and ANSI, others available on request
- working pressure: 1" to 4" at 360 PSI, 6" at 230 PSI
- minimum working temperature: **-320°F (-200°C)**

## Approvals:

- meet requirements for USCG 16715 CG-OES Policy Letter No. 02-15 use of dry disconnects and breakaway coupling/self sealing quick release
- conforms to ISO/DTS 18683 dimensioned for dry disconnects used for bunkering
- meets MSC 95/3/4 (IGF code) Section 8.5 Requirements for bunkering system
- meets the Society For Gas as a Marine Fuel (SGMF) Safety Guidelines for Bunkering
- DNV, NKK and BV type approved

# Cryogenic Dry Disconnect Couplings

## How It Works

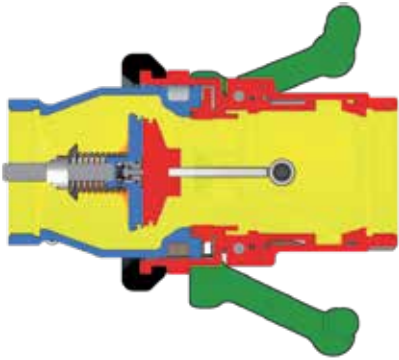

### To connect:

Push and turn - it's coupled at full flow

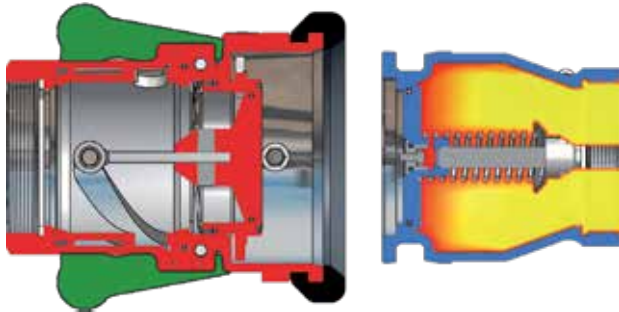

### To disconnect:

Turn and pull - it's released, no spillage

Dry Cryogenic couplings consist of a tank unit or adapter with a spring loaded poppet and a hose unit or coupler with a valve driven by an internal cam. To couple, simply align the rollers on the coupler with the notches on the adapter, push the coupler onto the adapter and rotate past 100 degrees. This simple process locks the coupling together, creates a self-seal and opens the internal valves for full flow with low pressure drop. The dual poppet design shut-off mechanism safely seals liquids and gases behind the valve eliminating fugitive emissions and the danger of a spill of cryogenic fluids.

## Flow Diagram

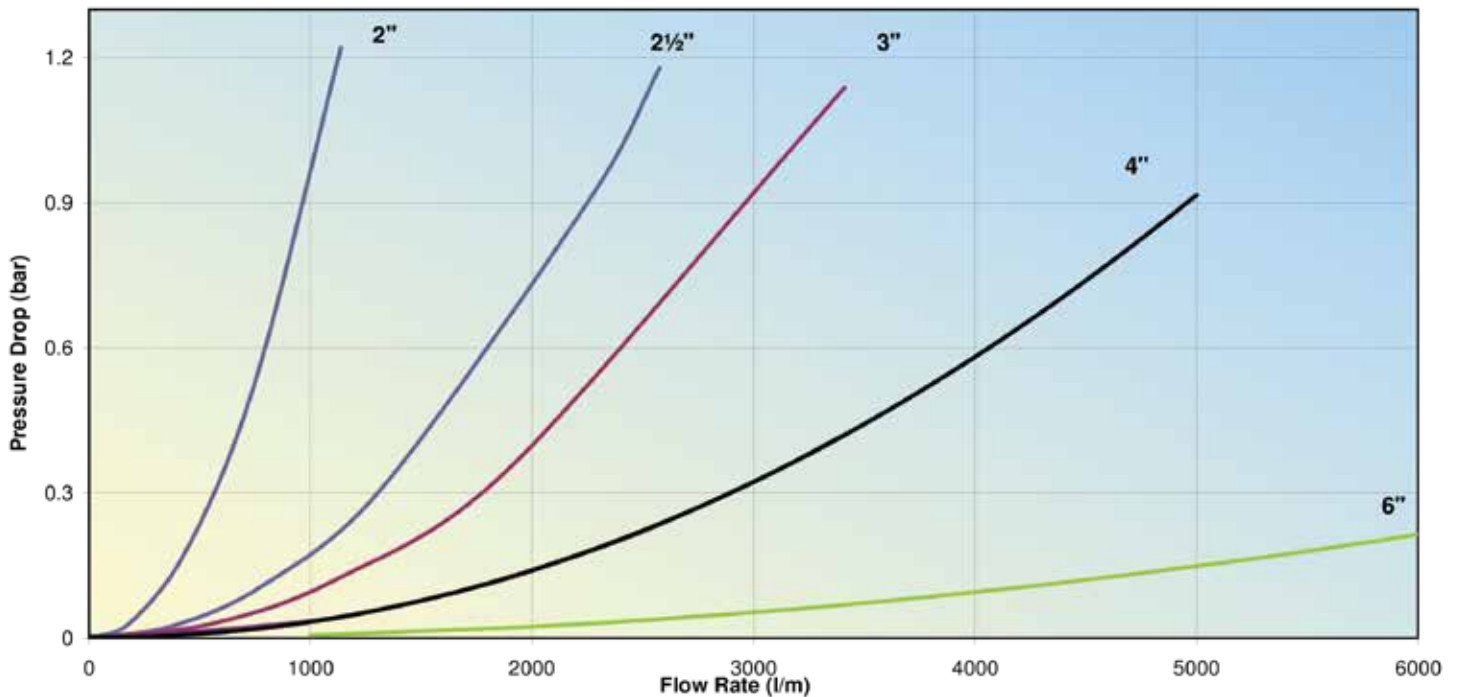

Test Fluid: LNG

Temperature: -256 °F

Density: 0.436 kg/dm<sup>3</sup>

Viscosity: 0.252 mm<sup>2</sup>/s

# Cryogenic Break-away Couplings



## Applications:

- container discharge
- fuel bunkering
- loading / unloading of tank trucks, rail cars and ship tankers
- vapor recovery lines

## Sizes:

- 1" - 6"

## Material:

- stainless steel

## Features:

- operates independently of shut-off safety system and does not require an external power source
- lightweight, easy to reset and repair on site with one person
- high flow rate / low pressure drop
- positive shut-off of both coupling halves results in minimum product loss
- passive security where a hose or loading arm could be subjected to inadvertent excessive loads
- can be installed at fixed points or in the middle of hose strings
- available as Industrial or Marine types
- no loose components which could be lost after release

## Specifications:

- connections: female NPT, flanged EN and ANSI, others available on request
- working pressure: 1" to 4" = 362 PSI, 6" = 232 PSI
- minimum working temperature: **-328°F (-200°C)**



# Cryogenic Break-away Couplings

## How It Works

The CBC couplings have three external break bolts. In the case of axial tension all of the bolts take up the force corresponding to the break force on the hose with a safety margin.

Non-axial forces concentrate the tension forces more strongly on one bolt, so that the safety break-away coupling reacts in a natural way to the reduction of the hose break forces.

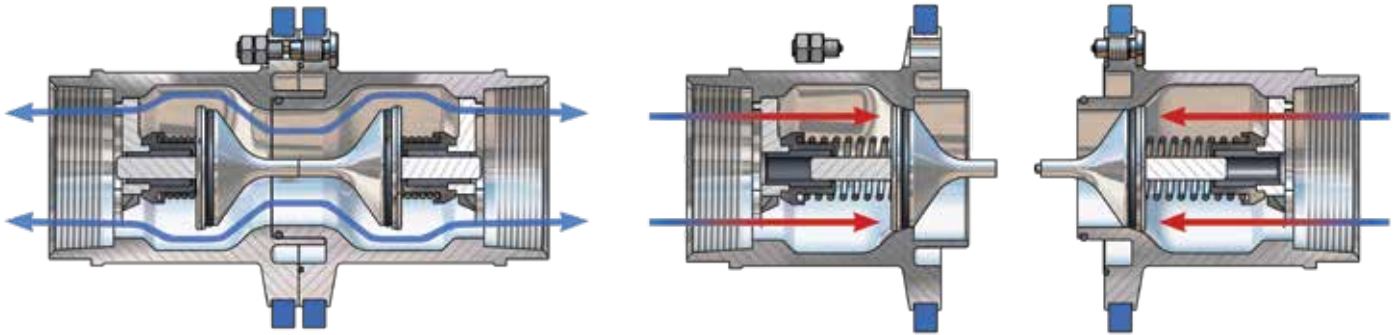

**BEFORE** emergency disconnect

**AFTER** emergency disconnect

The safety break-away valve consists of two halves, each with a valve that has an O-ring seal.

When the CBC couplings separate, it allows the valves to close. The two valves close rapidly, minimizing exposure to personnel and the environment.

## Flow Diagram

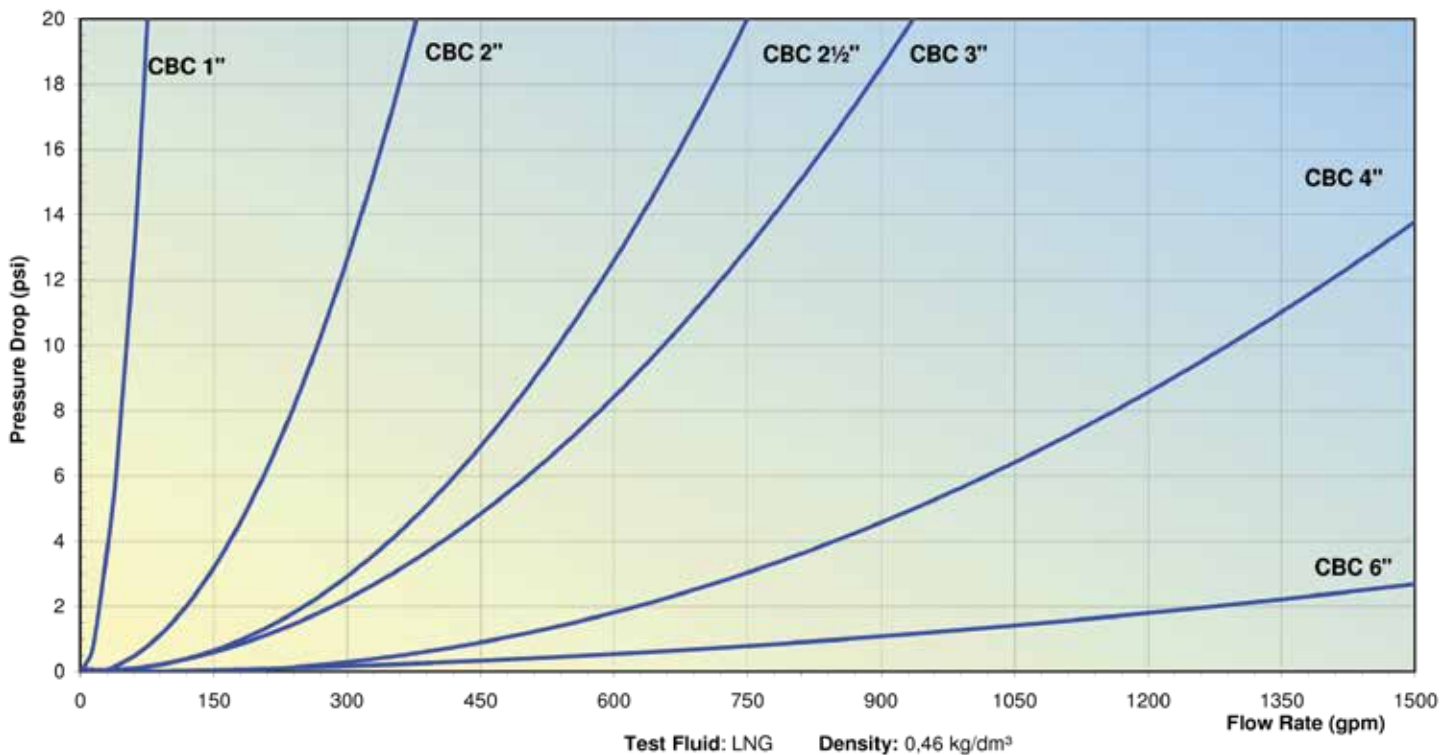

# Power Emergency Release Coupling (PERC)

## Applications:

- fuel bunkering
- loading / unloading of tank trucks, rail cars and ship tankers
- vapor recovery lines

## Sizes:

- 4" (DN100) to 8" (DN200), others on request

## Materials:

- stainless steel
- seal: PTFE

## Features:

- two halves close when there is excessive force or when pressurized Nitrogen is introduced to the coupling halves from a control unit to break the bolts and separate the couplings

## Specifications:

- calculation of the required wall thickness is made according to EN 12516-2
- material is suitable for use with LNG and nitrogen to **-320°F (-200°C)** according to the recommendations in EN1160
- 1.4404 conforms to specification EN10272
- 316L conforms to specification ANSI A479
- connections: NPTthread, EN1092 (DIN) or ANSI B16.5 flanges, others on request
- temperature range: **-320° F (-200°C) to 150°F (65°C)**
- recommended Nitrogen supply pressure: 200 Bar (min 150 Bar)
- recommended Nitrogen latent seal pressure: 2 Bar
- recommended tube / hose internal dimension: max 6.35 mm (¼")
- recommended tube / hose length: max 100m (smooth surface hose)
- time to release: < 2 sec
- gas consumption: max ~ 0.6 m<sup>3</sup>

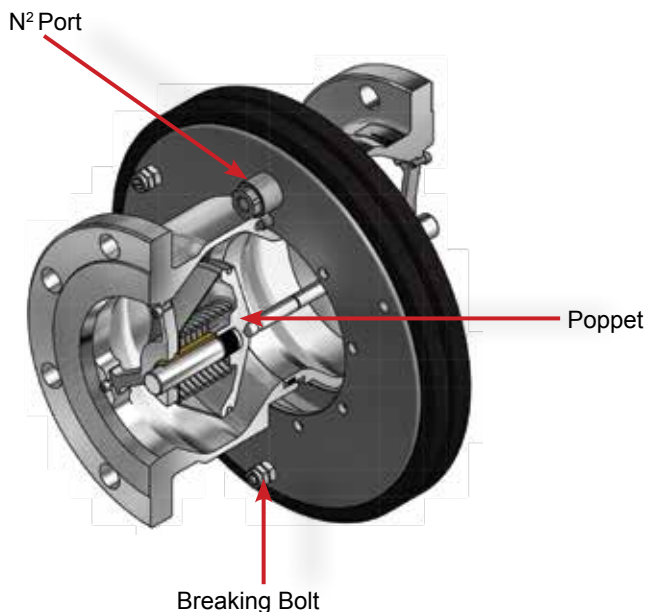

Size	Nominal Size	PSI	Standard Break Force (kN)	Max Break Force (kN)
4"	DN100	360 PSI	52	85
6"	DN150	230 PSI	92	132
8"	DN200	230 PSI	165	270

# Power Emergency Release Coupling (PERC)



Breaking Pin Type  
Break-aways

• **SAFE!**

• **SEPARATE ON  
COMMAND!**

The Mann Tek Cryogenic PERC design combines the passive safety feature known from our breaking pin type breakaways with the ability to separate on command without any force on the hose. When actuated by a remote control, a pressurized gas cylinder will open and gas pressure will overcome the breaking bolts. The PERC system corresponds to standard EN1474-1:2008

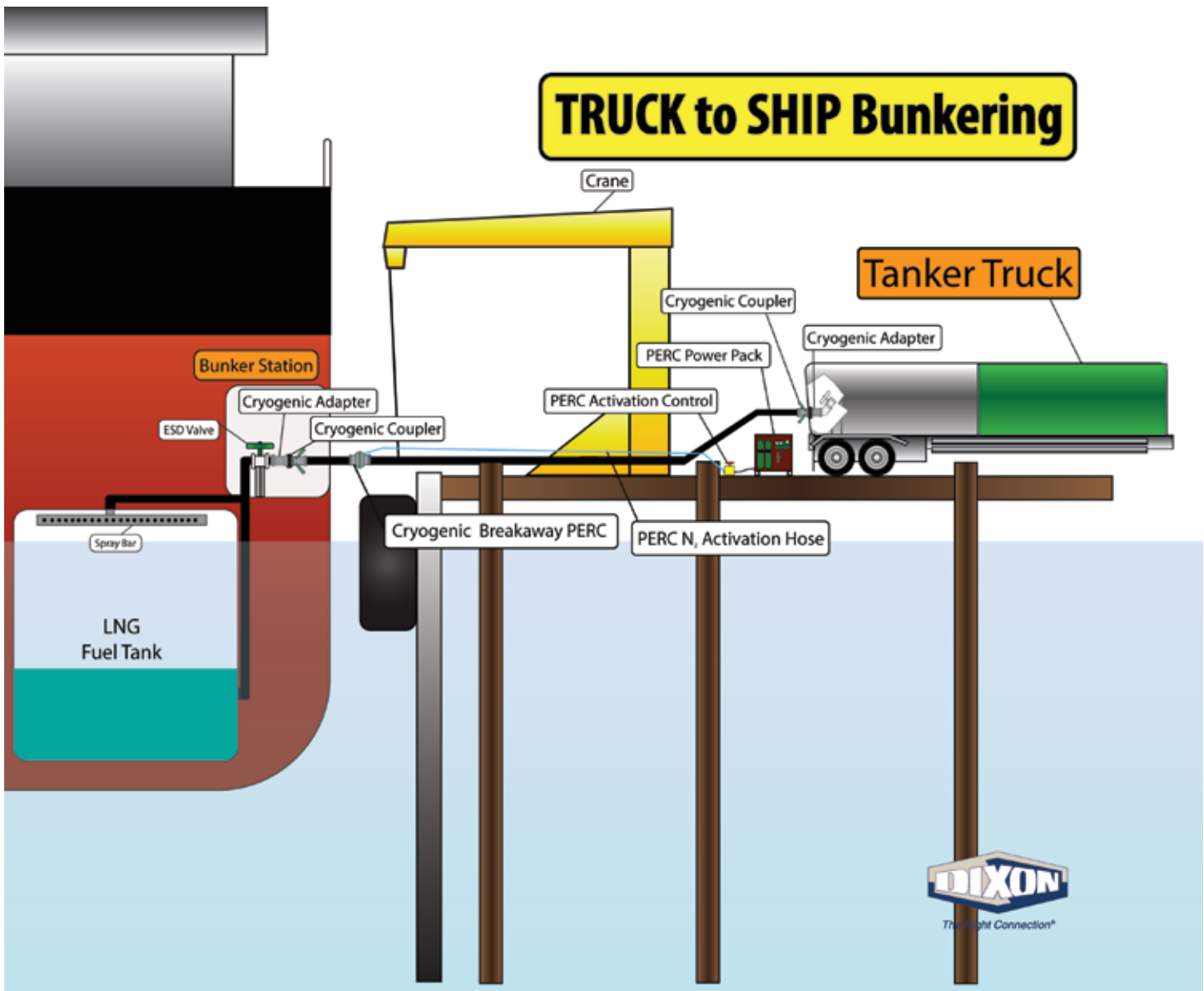



# Cryogenic Break-away Couplings - Cable Release

## Applications:

- plant engineering, power plant construction, chemical industry, food processing, process technology and tank cleaning
- filling systems: railroads, rail cars, tank trucks, ships, tank containers and liquefied gas

## Sizes:

- 1" (DN25) to 8" (DN200), others on request

## Materials:

- stainless steel
- seals: PTFE

## Features:

- sturdy design
- safe operation
- release angle up to 90° by cable activation
- maintenance friendly
- break force does not change with system pressure or angle of pull
- protects your system components by minimizing the amount of stress placed on your system

## Specifications:

- calculation of wall thickness is made according to SS-EN 12516-2
- material is suitable for use with LNG and Nitrogen to **-320° F (-200°C)** according to the recommendations in EN1160
- connections: NPT thread, EN1092 (DIN) or ANSI B16.5 flanges, others on request
- temperature range: **-320°F (-200°C) to 150°F (65°C)**
- pressure: PS25 Bar
- 1.4404 conforms to specification EN10272
- 316L conforms to specification ANSI A479

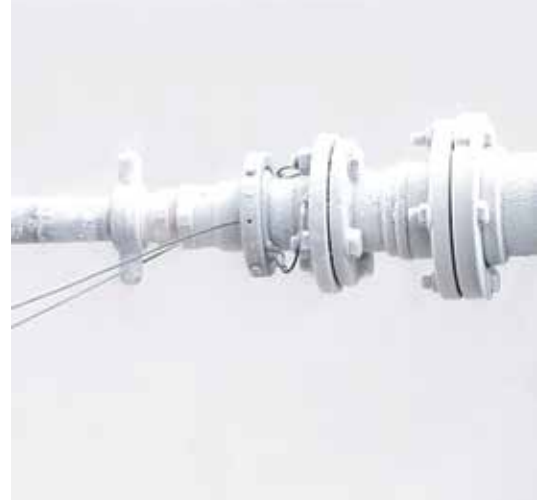

Size	Nominal Size	MAWP
1"	DN25	360 PSI
2"	DN50	360 PSI
3"	DN80	360 PSI
4"	DN100	230 PSI
6"	DN150	230 PSI
8"	DN200	230 PSI

# Cryogenic Break-away Couplings - Cable Release



Cable release series break-away couplings are designed to minimize spillage and damage associated with drive away and pull-away incidents. Couplings feature a simple mechanism and no loose components to lose after release. In some applications the necessary force of the breaking bolts may be too high to prevent damage to loading arms or other pipe and equipment; under these conditions the use of cable release safety break-aways may be more suitable.

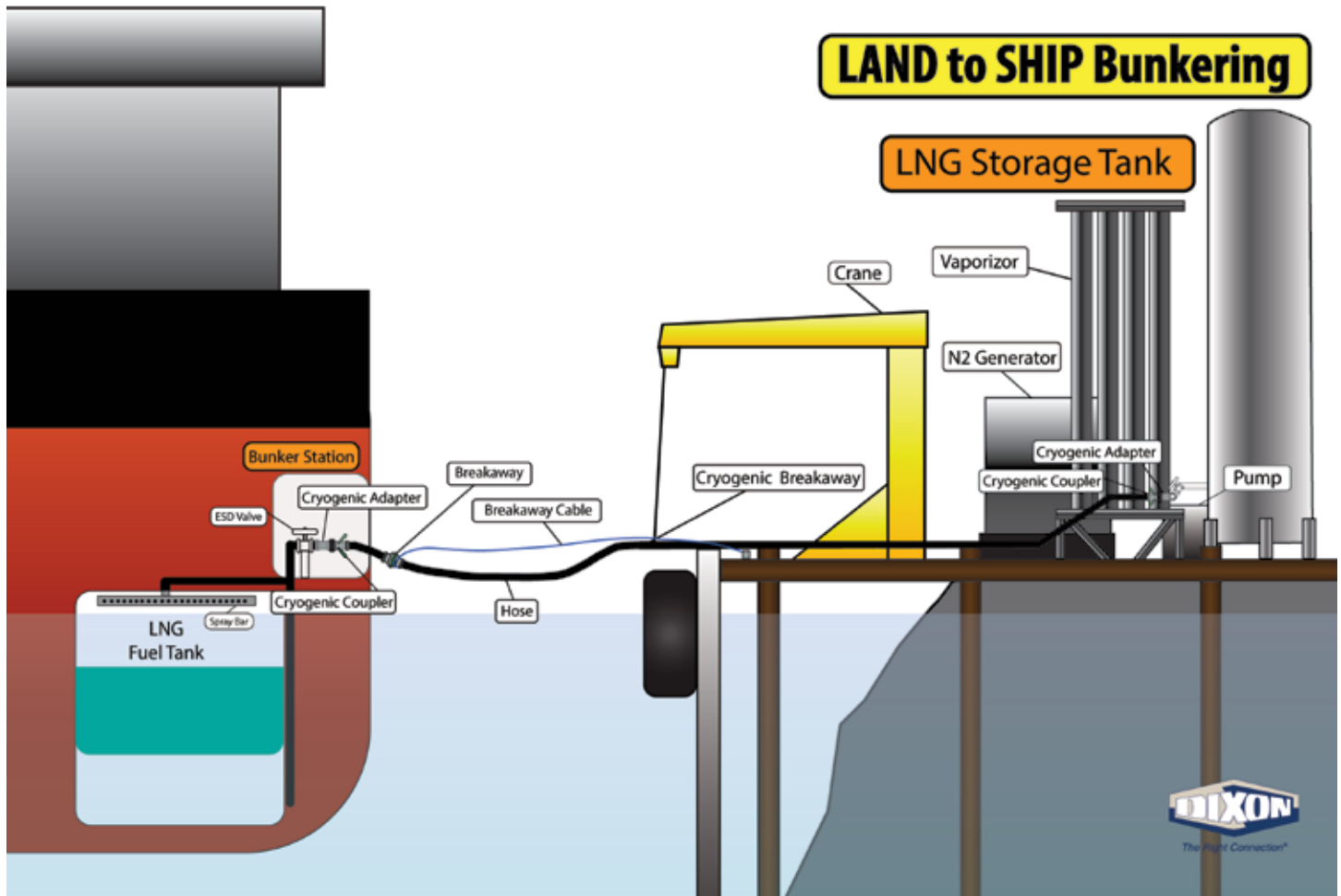

## Applications



Connecting 6" Cryogenic Coupler and Breakaway

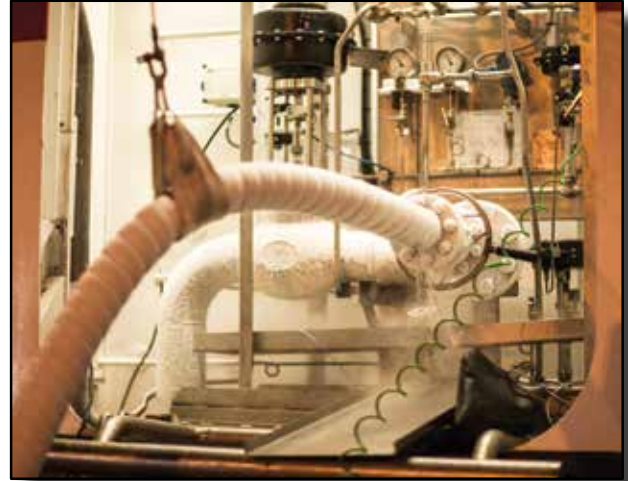

3" LNG Bunker Line



Disconnecting 3" Cryogenic Hose

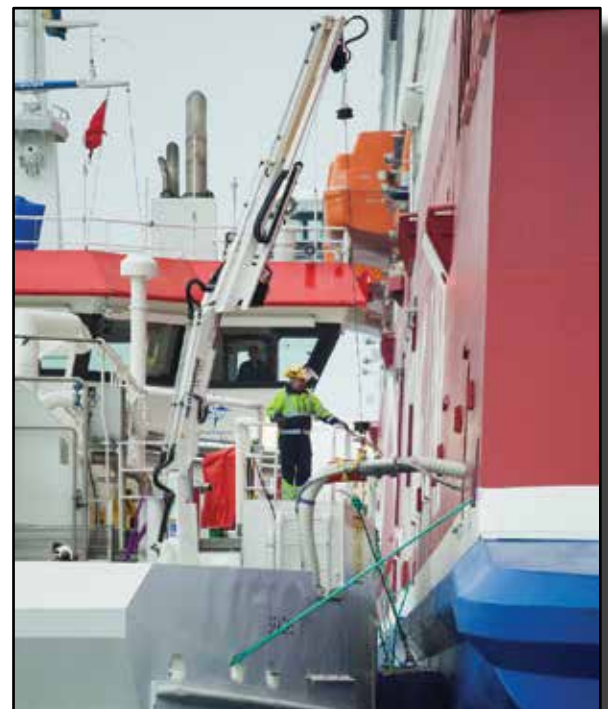

Bunker Vessel and Ferry

## Safety

Dixon® couplings and retention devices are designed to work safely for their intended use. The selection of the proper hose, coupling and retention device, and the proper application of the coupling to the hose are of utmost importance.

Users must consider the size, temperature, application, media, pressure and hose and coupling manufacturer's recommendations when selecting the proper hose assembly components. Dixon® recommends that all hose assemblies be tested in accordance with the Association for Rubber Products Manufacturers (ARPM) recommendations and be inspected regularly (before each use) to ensure that they are not damaged or have become loose. Visit [ARPMINC.com](http://ARPMINC.com) for more information.

Where safety devices are integral to the coupling, they must be working and utilized. The use of supplementary safety devices such as safety clips or safety cables are recommended. If any problem is detected, couplings must be removed from service immediately.

Dixon® is available to consult, train and recommend the proper selection and application of all fittings we sell. We strongly recommend that distributors and end users make use of Dixon®'s Testing and Recommendation Services. Call 877.963.4966 or click [canada.dixonvalve.com](http://canada.dixonvalve.com) to learn more.

Dixon®, founded in 1916, is a premier manufacturer and supplier of hose couplings, valves, dry-disconnects, swivels, and other fluid transfer and control products. The company's global reach includes a wide range of products for numerous industries including petroleum exploration, refining, transportation, chemical processing, food & beverage, steel, fire protection, construction, mining and manufacturing. Dixon®, strategic objective is to create solutions that make products safer, leak-free, longer lasting, and always available.

[canada.dixonvalve.com](http://canada.dixonvalve.com) • *Customer Service: 877.963.4966*



*The Right Connection®*

**Dixon Group Canada Limited®**

2200 Logan Avenue, Winnipeg, MB R2R 0J2  
[isales@dixongroupcanada.com](mailto:isales@dixongroupcanada.com)



FOLLOW US



DIXON CANADA  
CUSTOMER SERVICE